



啓碩機械廠有限公司
CHI-SHUN MACHINERY PLANT CO.,LTD.

APD 系列
APD SERIES

全自動高分子聚合物泡藥設備
AUTOMATIC POLYMER PREPARATION SYSTEMS



榮獲
ISO 9001
國際品質認證

創新 Innovation
質量 Quality
效能 Efficiency
安全 Safety



啓碩機械廠有限公司
CHI-SHUN MACHINERY PLANT CO.,LTD.

台灣台南市歸仁區大順街306號 郵編：71148 ADD：No.306,Dashun St,Gueiren Dist,Tainan City 71148,Taiwan
TEL 電話：+ 886 6 2392501 FAX 傳真：+ 886 6 2391759
E-mail：chishun.com@msa.hinet.net Web site 網站：www.chishun.com.tw

廣州啓碩機械設備有限公司 廣州地址：廣州市珠海區昌崗中路172號星都大廈9009室
電話：020-34108989·84328839 傳真：020-34108996
E-mail：zqh-1212@163.com 網站：www.chi-shun.com

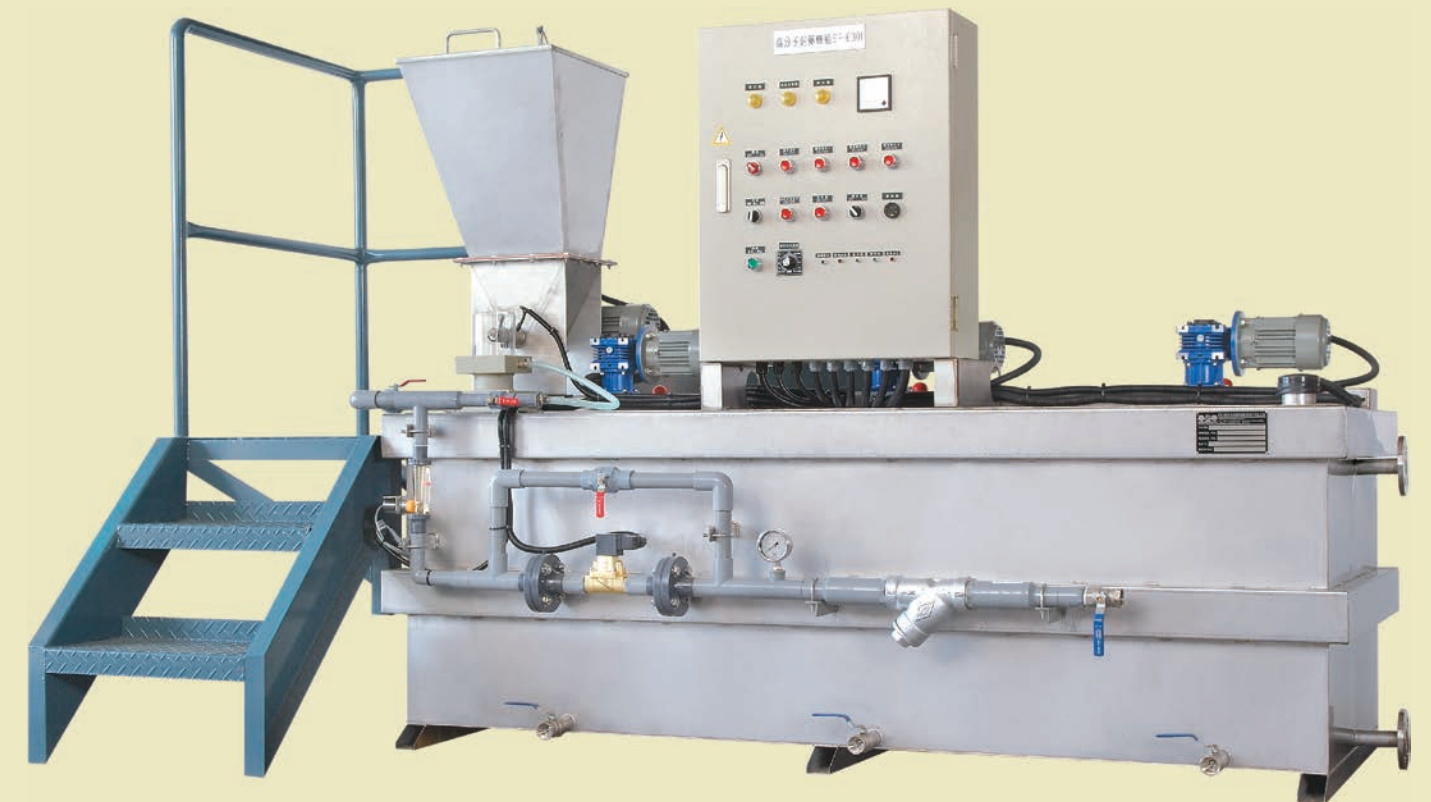

APD SERIES

代理/經銷商 DISTRIBUTOR

CHI-SHUN



關於啓碩

1983年，台灣啓碩機械廠有限公司創立於台灣的台南縣，二十多年來致力於高質量廢水處理設備，集研發、設計、製造、銷售及服務於一體，生產各種廢水處理設備；包括了污泥濃縮機、污泥濃縮脫水一體機、板框式污泥脫水機、粉體自動泡藥機、加壓快速浮除設備、自動攔污柵、污泥焚化乾燥系統...等。

為提升污泥脫水設備的品質及效能，並在設備各方面取得突破性發展，啓碩於1988年領先同業引進德國優秀的固液分離技術，結合啓碩自身先進的機械制作與精密加工不斷求新求變，研發出新一代的NBD系列--全自動滾筒式/帶濾式污泥調理·濃縮·脫水·三機一體系列及CS型自動攔污柵、BS型自動攔污柵、**APD型全自動高分子聚合物泡藥設備**躍身成爲污水處理設備之領導廠商。在公司持續不斷的研發中，產品多次獲得台灣經濟部及工業部所頒發的優質環保設備獎，並取得多項設計專利。

因應專業性與國際性共通的標準化，為滿足顧客要求和適用法規的能力，啓碩更於2000年通過ISO 9001國際質量認證。所生產的設備行銷到世界各國，如美國、加拿大、英國、澳大利亞、西班牙、墨西哥、中國、印度、新、馬、印、泰、越等二十多個國家並獲得良好口碑，同時也得到如豐田汽車、雀巢公司、統一企業、奧林巴斯、日月光...等世界知名企業的一致好評。

啓碩機械所生產的各類廢水處理設備，應用範圍廣泛能適用於各種產業廢水，如紙漿業、印染業、電鍍業、皮革業、金屬加工業、石材業、城市混合污泥、城市剩餘活性污泥、混合污泥...等。

創新、質量、效能和安全是我們的基本原則，而對於品質的嚴格要求，一直是啓碩對客戶的承諾與驕傲所在，未來我們也將持續不斷的突破與創新，與世界各地朋友合作爲環境保護和社會進步盡一份心。

給世界一個乾淨的環境

GIVE THE WORLD A CLEAN ENVIRONMENT

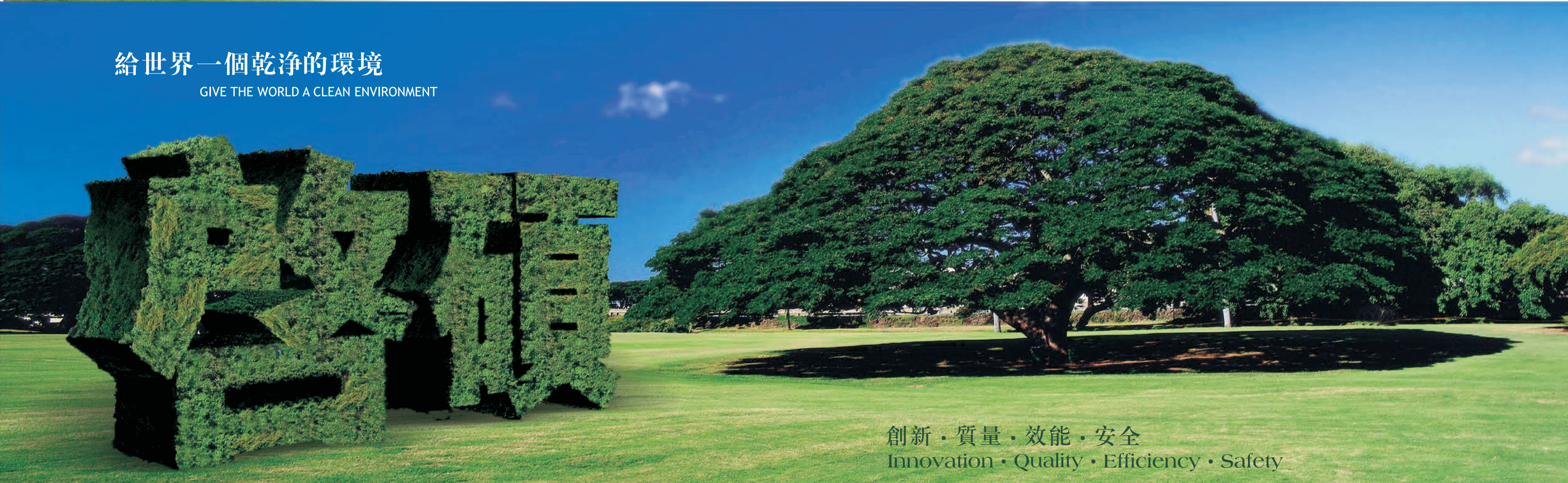

創新·質量·效能·安全

Innovation · Quality · Efficiency · Safety

Since founded in 1983, **CHI SHUN MACHINERY PLANT CO., LTD.** has devoted to the professional manufacturing of sludge and wastewater treatment. With over 20 years of design, manufacturing and marketing experience, our products and services have throughout the world and are enjoying a good reputation.

Our products including DRUM THICKENER SYSTEM, BELT FILTER PRESSES, FILTER PRESSES, POLYMER PREPARATION SYSTEM, DISSOLVED AIR FLOTATION, BAR SCREEN and SLUDGE DRYER.

For breakthrough in high quality, efficiency and good shape of wastewater treatment; **CHI SHUN** adopted newest skills from Germany, and then we created the whole new belt filter presses.

Continuous improvements of product quality and reliability have always been our first priority. In 2001, **CHI SHUN** is Taiwan's first manufacturer in the industry to be certified by AFAQ-EAQA to comply with Quality Management System requirements of ISO 9001:2000. We also obtain the Taiwan excellence product and patent licenses from economic Ministry. Now **CHI SHUN** has become the leading manufacturer of wastewater treatment systems throughout Asia.

Furthermore, we are an international provider of integrated wastewater treatment solutions, offering equipment, systems and services throughout the world.

Equipment can be provided either standard-alone or as part of complete system to treat municipal, industrial and any process wastewater.

Innovating, high quality, high efficiency and use friendly are our features. We strive to produce high quality machines and maintain its low cost. Our onsite services and warranty will provide you with complete peace of mind and absolute satisfaction. With us, you are in good hands. Please do not hesitate to contact us if you have any questions or require any additional information.

ISO

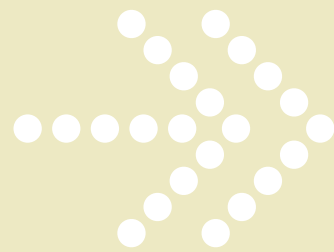

實力認證

Qualit Certification



84年專利證書
Patent license in 1995



87年專利證書
Patent license in 1998



90年專利證書
Patent license in 2001



92年專利證書
Patent license in 2003

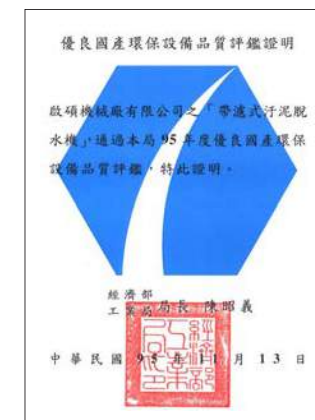

優良環保設備證書
Obtain the taiwan
excellence product from
economic ministry



優良環保設備獎牌
Obtain the taiwan
excellence product from
economic ministry



大陸證書
Obtain the environmental
protection equipment
from china



ISO 9001證書
Obtain ISO 9001
certification

處理流程圖 Flow Sheet

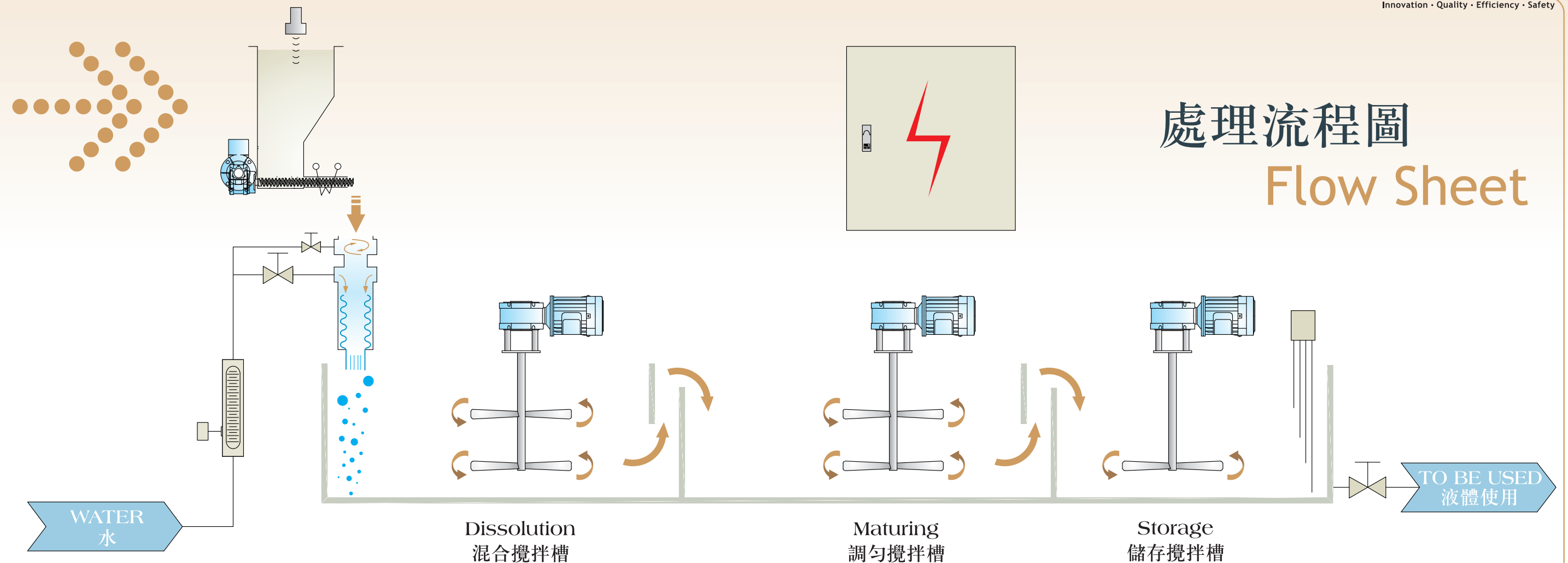

設備簡介

APD-系列高分子全自動泡藥設備是設計應用在污水處理及其他工業的程序上；
 APD-系列是根據各種工藝設計所需濃度，將乾藥粉加入使其產生液體，並與污水混合絮凝，使固體物達到最大值以增加處理效果。此設備也縮短了沉澱或浮除濃縮時間及脫水的時間。
 APD-系列高分子全自動泡藥設備的使用運用範圍沒有限制，包含了市政及各種工業污水處理例如：沉澱、浮除、石油化學、硫酸鹽、電鍍、造紙及其他等工藝。

機械特點

- 1 完全以不銹鋼304材質及耐腐蝕材質製成。
- 2 全自動化操作保證產生最高效率及最低操作維護成本。
- 3 可程式PLC控制提升可靠穩定性且最人性化操作。
- 4 濃度範圍可調整選擇(0.1~0.4%)
- 5 儲存斗頂部加防塵蓋及粉位監測器可確保粉體輸出的穩定及安全性。
- 6 創新的濕潤混合裝置設計可防止結塊及混合不均。
- 7 螺旋輸送設備家裝加熱器，連續加熱保持溫度使粉體乾燥不結塊。
- 8 全方面的控制面板顯示運轉的狀態。
- 9 三槽式的設計可快速泡製、熟化及儲存以供應連續使用。

Introduction

APD-Series Automated Dry Polymer Preparation System is designed for applications such as wastewater treatment and other industrial processes. APD-Series prepares dry powder polymer into selected liquid concentrations for various process needs in order to maximize the flocculation and conglomeration of solids. It also reduces the duration of a particular process such as settling, flotation, or dewatering.
 APD-Series Automated Dry Polymer Preparation System has no limits in whether municipal or industrial wastewater treatment applications, unit processes such as settling, flotation, dewatering, petrochemical, sulfonation, electroplating, and pulp & paper and others etc.

Features

- 1 All 304 SS construction along with corrosion resistant materials such as PVC, PP.
- 2 Automated operation assuring consistent output and minimum O&M costs.
- 3 PLC controller to increase reliability and ease of operation.
- 4 Widely adjustable concentration range (0.1%~0.4%).
- 5 Covered hopper along with power level monitoring assuring reliable and consistent results.
- 6 Innovative wetting assembly assuring zero gelling potential.
- 7 Heated conveyor to prevent gelling potential around metering screw.
- 8 Comprehensive local control panel indicating operating status.
- 9 Multi-tank design for flash mixing, aging, and storage needs.

APD

高分子全自動泡藥設備
Automatic Polymer Preparation Systems

CHI-SHUN
Innovation · Quality · Efficiency · Safety

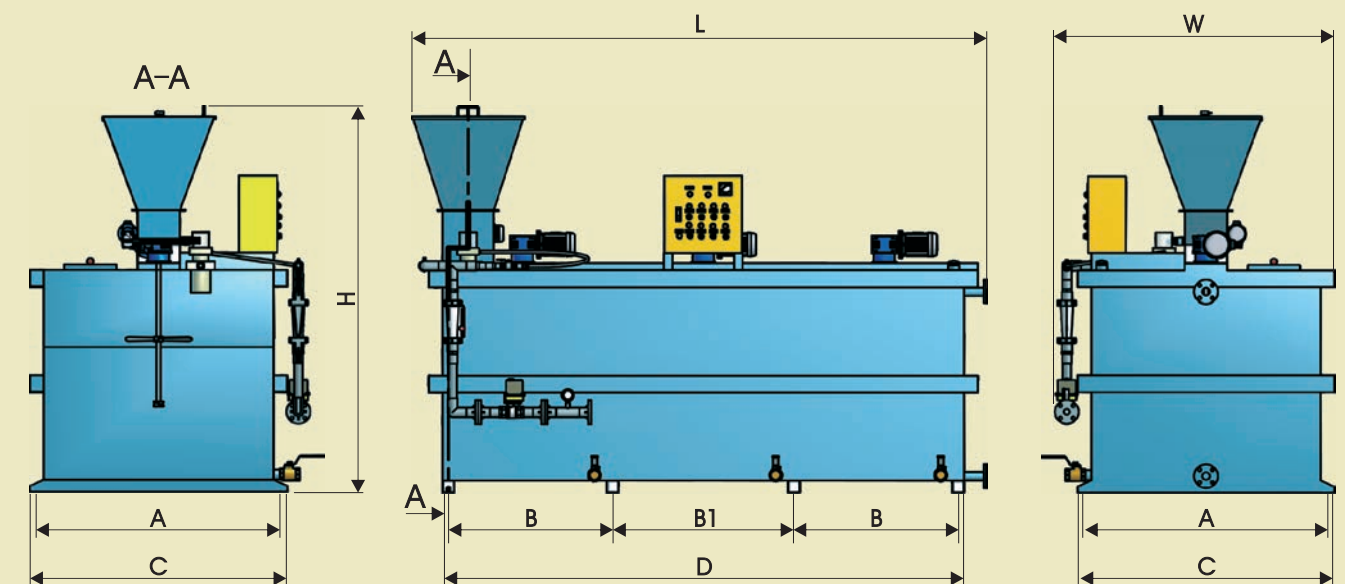
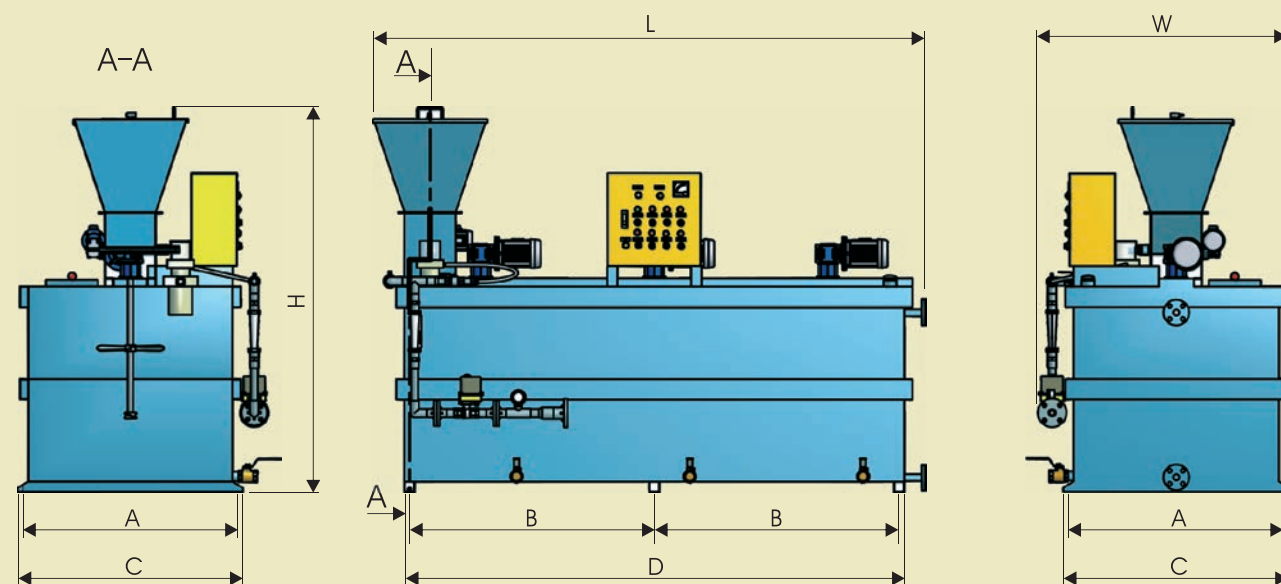
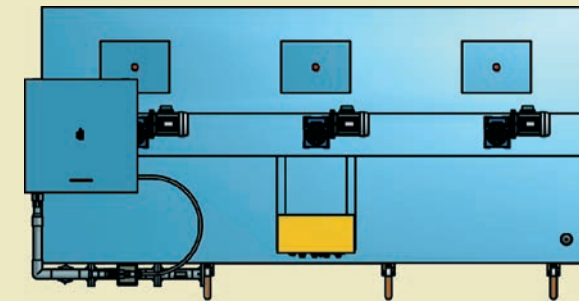
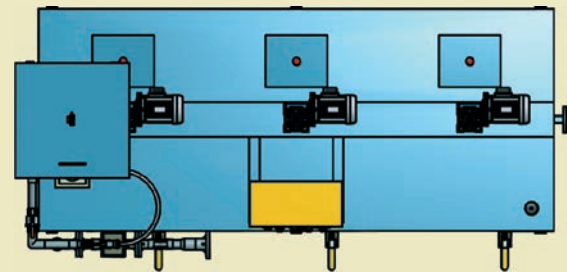

APD- 500~2000 技術規格參數 Technical Data

機型 Model	污泥處理量 Capacity (L/hr)	粉體儲槽 Storage Hopper (L)	使用功率 Use Power				外形尺寸 Dimensions (L.W.H) mm	基座尺寸 Basic (A,B) (C,D) mm	重量 Weight (KG)
			螺旋輸送 Screw (HP)	混合攪拌槽 Dissolution (HP)	調勻攪拌槽 Maturing (HP)	儲存攪拌槽 Storage (HP)			
APD-500	500	50	1/4	1/3	1/3	1/3	1880 795 1505	650x825 700x1700	340
APD-1000	1000	50	1/4	1/3	1/3	1/3	2198 1020 1605	850x984 900x2018	450
APD-1500	1500	50	1/4	1/2	1/2	1/2	2408 1020 1753	850x1089 900x2228	570
APD-2000	2000	80	1/4	1/2	1/2	1/2	2695 1225 1875	1050x1195 1100x2440	720

※ 可依渠道尺寸量身製作 customize according to dimensions

APD- 3000~10000 技術規格參數 Technical Data

機型 Model	污泥處理量 Capacity (L/hr)	粉體儲槽 Storage Hopper (L)	使用功率 Use Power				外形尺寸 Dimensions (L.W.H) mm	基座尺寸 Basic (A,B, B1) (C,D) mm	重量 Weight (KG)
			螺旋輸送 Screw (HP)	混合攪拌槽 Dissolution (HP)	調勻攪拌槽 Maturing (HP)	儲存攪拌槽 Storage (HP)			
APD-3000	3000	80	1/4	1/2	1/2	1/2	2975 1210 2075	1050x860x950 1100x2720	980
APD-5000	5000	120	1/4	1	1	1	3360 1635 2260	1420x960x1060 1500x3050	1280
APD-7000	7000	120	1/4	1	1	1	3750 1820 2262	1605x1100x1170 1685x3440	1650
APD-10000	10000	160	1/4	2	2	2	4675 1820 2667	1605x1380x1480 1685x4340	2150

※ 可依渠道尺寸量身製作 customize according to dimensions

APD型高分子全自動泡藥設備產品介紹

各項生產設備介紹

Products

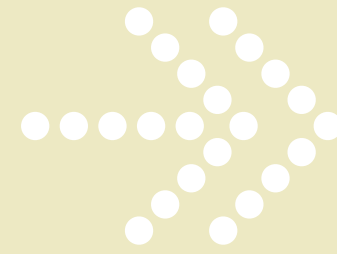

1 板框式污泥脱水機
Filter presses

2 加壓快速浮除設備
Dissolved air flotation

3 全自動滾筒式/帶濾式污泥調理·濃縮·脱水·三機一體
Automatic belt press with rotary drum screen

4 粉體自動泡藥機
Polymer preparation systems

5 自動攔污柵
Bar screen

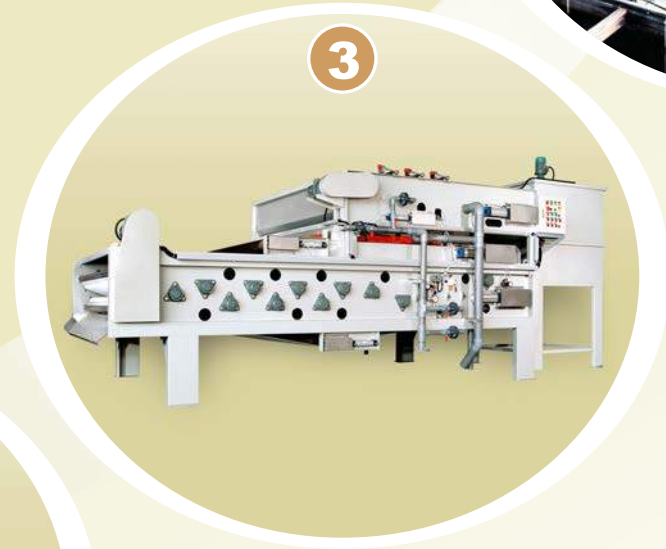
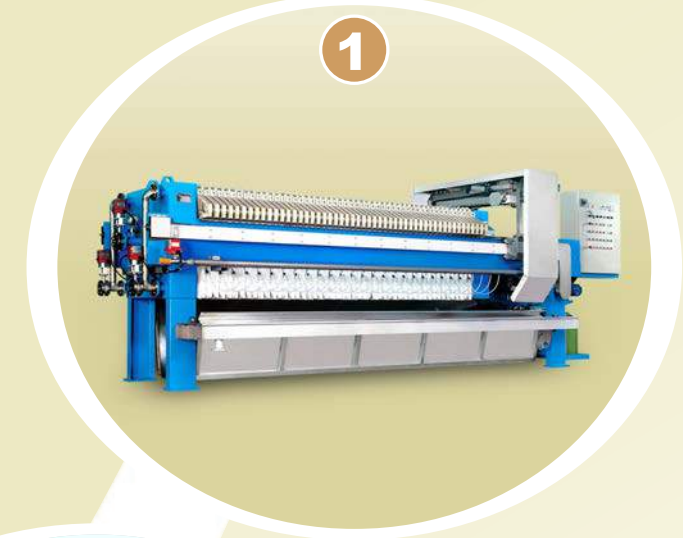

創新 · 質量 · 效能 · 安全
Innovation · Quality · Efficiency · Safety